

HS

TECHNICAL DATA



Model : HS



Model : HS-5/8



- Light and Manoeuvrable
- Compact
- Easy to operate
- Silent in operation
- Economical
- Minimum maintenance
- Versatile

Full Function Control Handle

Hand lowering is the key to productivity. The loads are conveniently deposited by three position (Lift, Neutral and Lower) control handle.

The ergonomically designed handle makes lifting loads and steering easier.

The neutral position eliminates back pressure from the pump thus allowing the operator to handle the load with ease.

The spring-loaded handle returns to vertical position when released.

A few strokes of the handle provide a full lift of 1600 mm.

Wheels

Steering and support wheels : 2 Nylon wheels \varnothing 180 x 50 mm
 Load Wheels : 4 Nylon wheels \varnothing 82 x 70 mm

Model : HS-10/12



Salient Features

PUMA Stackers - an indispensable auxiliary for all type of industries.

HS-5/8/10/12 are extremely versatile manually operated stackers. They are very useful for Loading, Unloading and Stacking operations. With a detachable platform on the fork they can be also used as an adjustable work table. (Option)

SPECIFICATIONS								
Model	HS-5		HS-8		HS-10		HS-12	
Basic Load Capacity	500 kgs		800 Kgs		1000 Kgs		1200 Kgs	
Mast type	Mono	Tele	Mono	Tele	Mono	Tele	Mono	Tele
lowered Height (mm)	90	90	90	90	90	90	90	90
Lift Height (mm)	1600	2000	1600	2000	1600	2000	1600	2000
Shut Height (mm)	2050	1600	2050	1600	2050	1600	2050	1600
Extended Height (mm)	-	2525	-	2525	-	2525	-	2525
Capacity at Max. Height	500Kgs	400Kgs	800Kgs	650Kgs	1000Kgs	700Kgs	1200Kgs	800Kgs

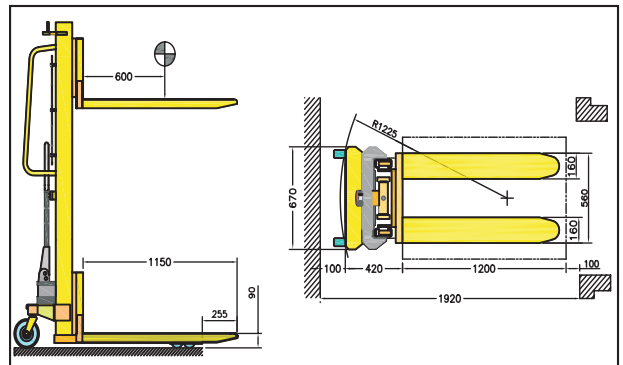

PUMA LIFT TRUCKS PVT. LTD.

Plot No. 265/1B & A-69 (KSSIDC),
 Bommasandra Industrial Area,
 Bangalore - 560 099, India.

Telefax : +91-80-2783 4455 / 5785
 +91-80-2783 6085 / 6088 / 6555
 E-mail : info@pumalift.net