

RS

Reach Stacker



Model : RS 10 Technical Data



The Reach Stacker can be used wherever load arms stackers can not operate. With a compact turning radius and a good manoeuvrability, the truck can operate with ease in confined warehouse areas. The frame is made of high-strength steel components with extremely good torsional rigidity and provides easy access for servicing work. Easy to operate and economical to buy. It is the ideal solution for short-distance operation and medium lifting heights. Drive and lifting electrical motors are designed for high sustained output performance.

SPECIFICATIONS		
Parameters	Unit	Specification
Basic Capacity	Kg's	1000
Mast		Telescopic
Load Center	mm	600
Fork Size (L x W)	mm	1150 x (250 to 685) adjustable
Each Fork Width	mm	100
Overall Length	mm	2550 + 490
Overall Width	mm	950
Outer Turning Radius without P/F &	mm	1800
Reach Length	mm	500
Working Aisle in b/w Racks	mm	2800mm
Capacity at Full Height	Kg's	800
Drive Motor-AC / Make	V/KW	24 x 1.5 / KDS
Hydraulic Pump Motor / Make	V / Kw	24 x 3 / Winner
Battery	DC, V/Ah	24 x 330
Brake		Electromagnetic
Drive Control		Mosfet
Gradability Laden / Unladen	%	4 / 6
Travel Speed Laden / Unladen	Km/hr	3 / 4
Wheels		
Polyurethane Drive Wheel	mm	230
Polyurethane Support Wheels	mm	125
Polyurethane Load Wheels	mm	250

Chassis & Mast

- Rounded contours, no sharp edges
- Highly resistant, robust steel construction
- Rigid clear view mast optimizes visibility
- Wide choice of masts

Dependability

- Tough counterbalance performance.
- Comprehensive selection of mast configurations.

Productivity

- Compact chassis design improves handling in confined spaces.
- Regenerative braking and anti-roll back as standard.
- Adjustable performance settings to suit specific operating conditions.

Cost of ownership

- Powerful AC traction motor provides superior performance and increased load moves per hour.
- Increased load moves per hour reduces operating costs

Serviceability

- Hour meter and battery discharge indicator with lift interrupt fitted as standard.
- Electrical system and wiring are protected to EU standards, ensuring greater reliability over time

Braking System

- Automatic braking
- On releasing the traction butterfly, with no energy consumption
- By selecting opposite direction of travel
- Emergency brake
- Electro-Magnetic
- On pressing the emergency button

Energy

- Powerful battery of 24V, 330Ah
- Efficient battery locking system for side change option secures battery in compartment
- Battery rollers.
- Battery discharge indicator
- Lift lock when the battery is at low charge for longer life time

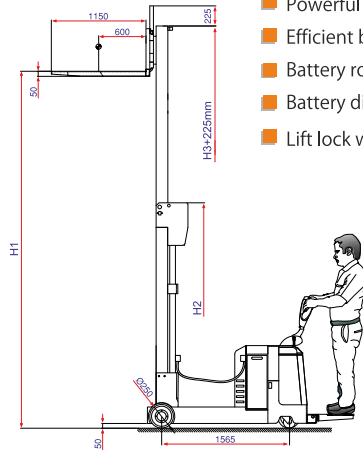
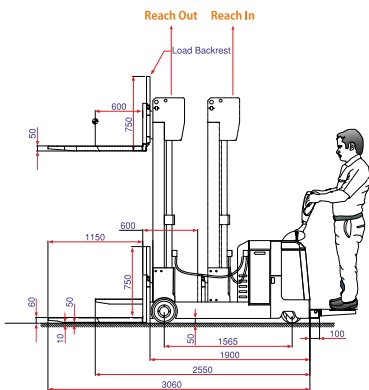
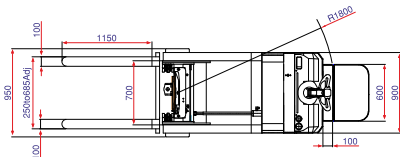

MAST SPECIFICATIONS IN MM		
LIFT HEIGHT (H1)	SHUT HEIGHT (H2)	EX-HEIGHT (H3)
1600	2175	2175
2000	1625	2575
2850	2050	3425
3200	2225	3775
3600	2425	4175
4000	2650	4575